

## Design for Testability Guidelines

### Conventional and EC-1 In-Circuit Test Fixtures

Revision F – August 20, 2001

**1. All test targets are preferred to be on one side of the PCB.**

ECT is quite capable of equipping fixtures with topside probing, but targeting accuracy is slightly diminished due to the additional tolerances involved.

**2. Test Target-to-Component Spacing**

The following guidelines represent the minimum spacing allowed for placing probes relative to SMD components on the side of the board being tested. These guidelines are based on fixture drilling requirements and do not reflect any board related keep-out requirements around the component, which may limit the spacing to a distance greater than that specified below.

*In the following figures, the “component” geometry refers to the component placement boundary. Thus, all dimensions are from the edge of the component placement boundary to the center of the test target.*

*The minimum probe-to-component distances identified below are based on the use of 100 mil Pogo probes. Tighter spacing may be achieved by using 75 mil or 50 mil Pogo probes.*

*All dimensions shown are in inches.*

**Conventional Fixture  
Standard Top Plate  
Component Height <.125”**

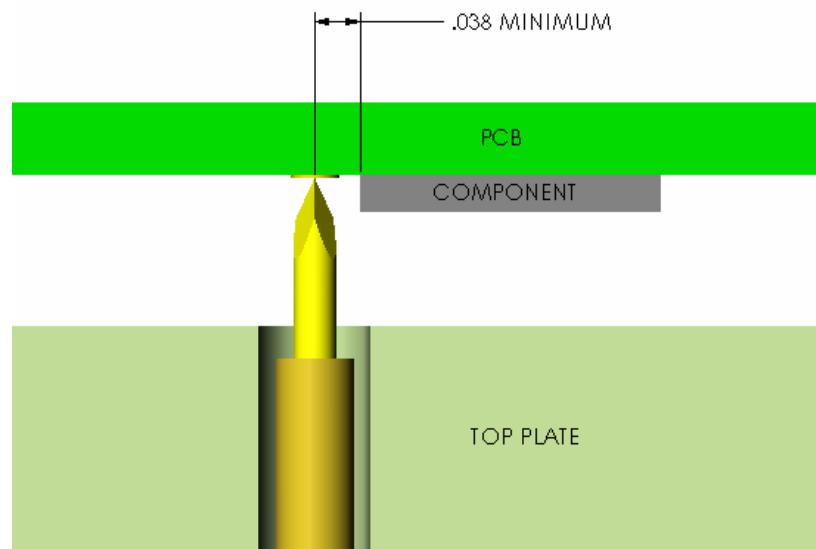

**Conventional Fixture  
Standard Top Plate  
Component Height > .125"**

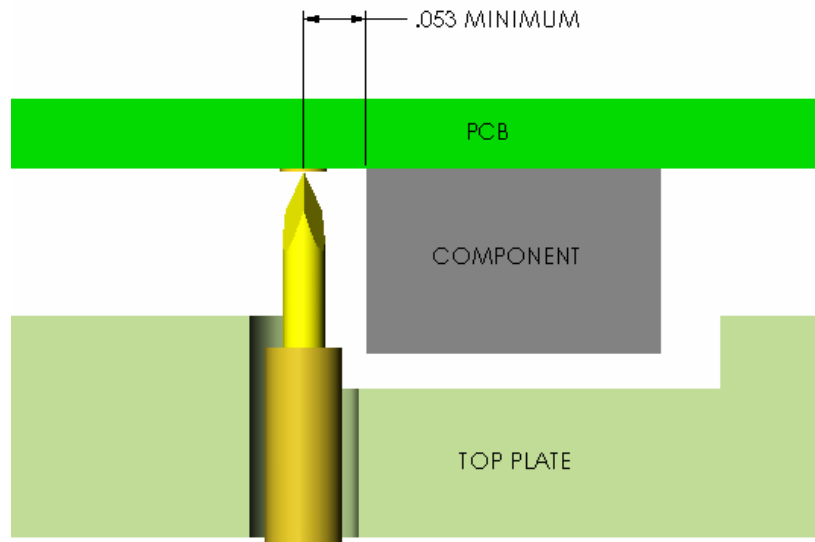

**Conventional Fixture  
Guided Probe Top Plate  
Component Height < .050"  
Manual/Automated Zeroflexing**

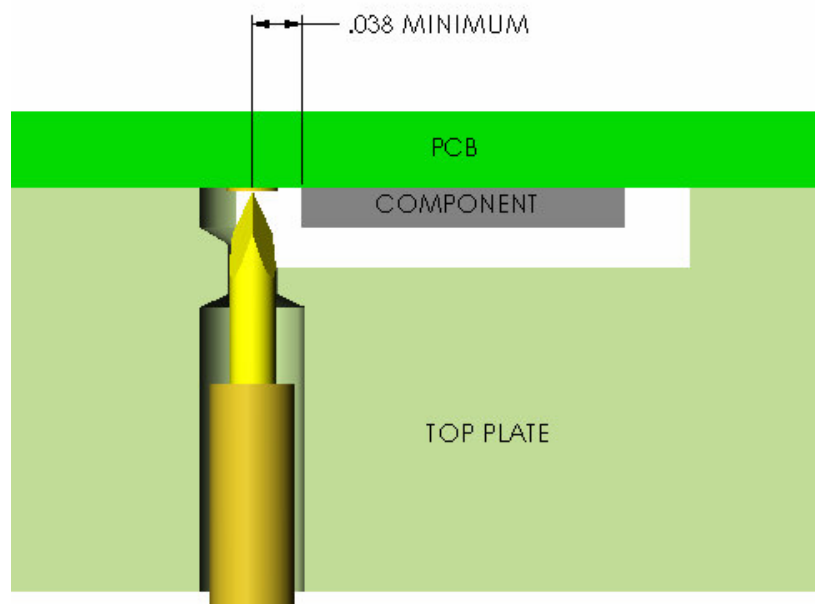

**Conventional Fixture  
 Guided Probe Top Plate  
 Component Height > .050"  
 Automated Zero-Flexing**

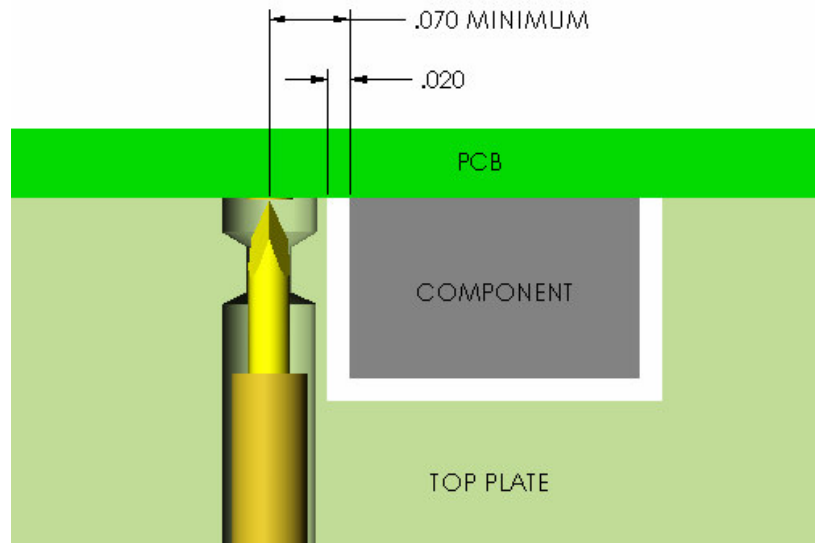

**Conventional Fixture  
 Guided Probe Top Plate  
 Component Height > .050"  
 Manual Zero-Flexing - Digitized Component Locations**

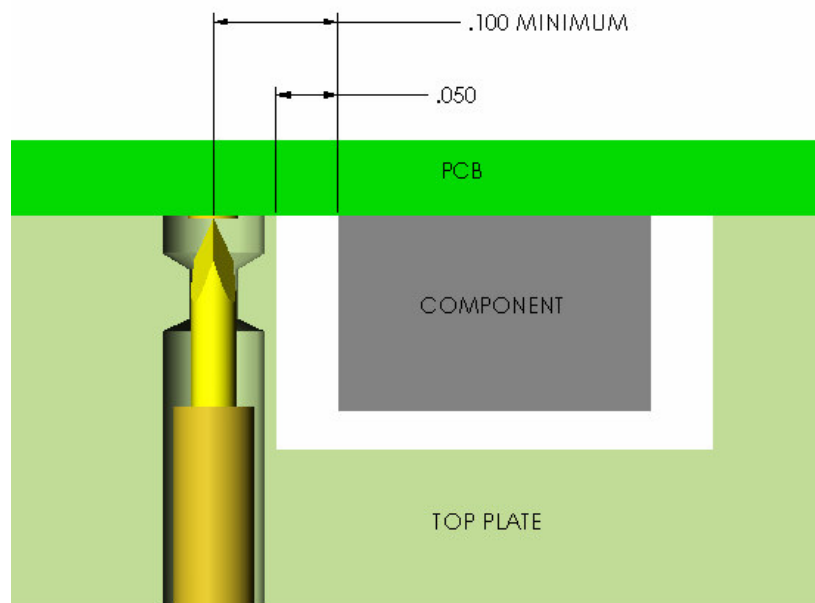

**EC-1 Test Fixture**  
**Guided Probe Top Plate**  
**Component Height < .200"**  
**Manual/Automated Zeroflexing**

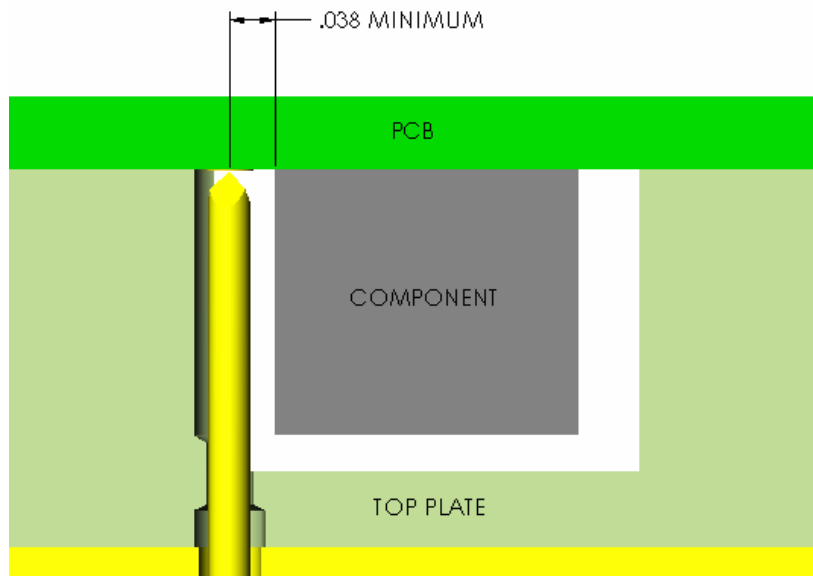

**EC-1 Test Fixture**  
**Guided Probe Top Plate**  
**Component Height > .200"**  
**Automated Zero-Flexing**

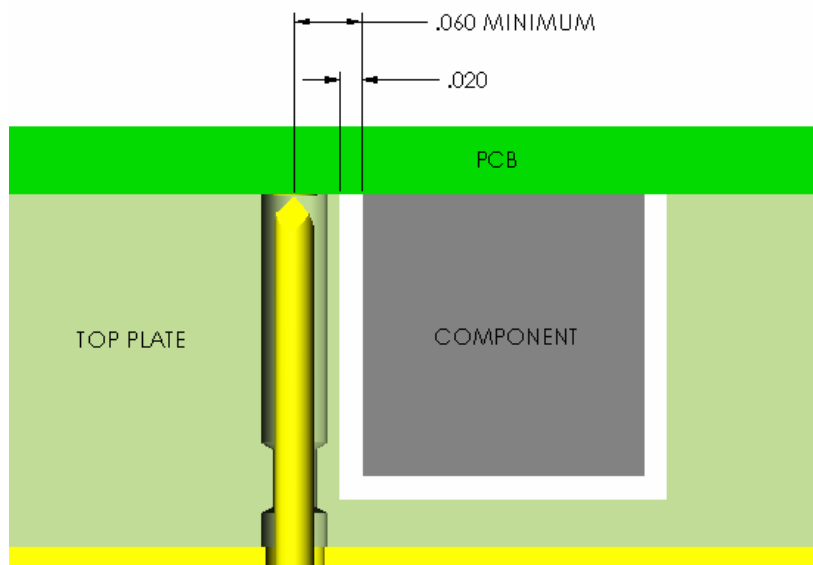

**EC-1 Test Fixture  
Guided Probe Top Plate  
Component Height > .200"  
Manual Zero-Flexing - Digitized Component Locations**

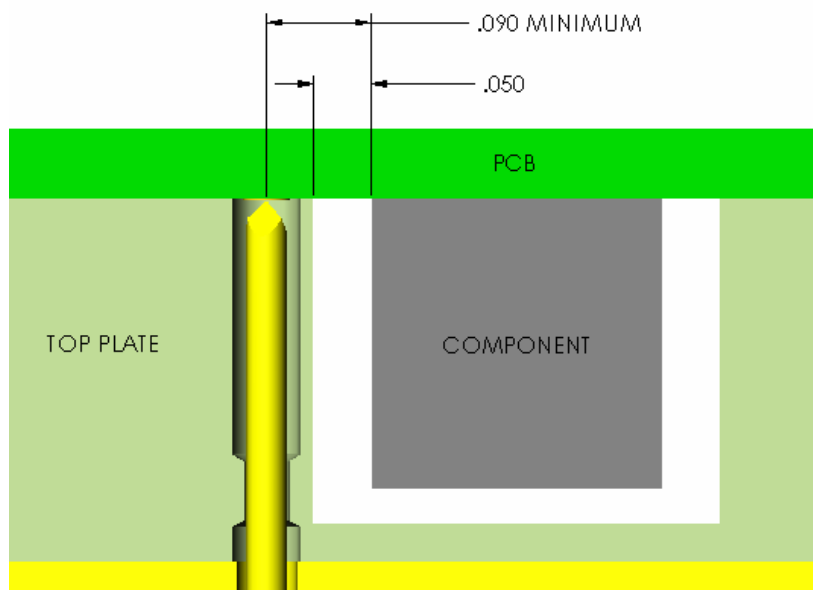

**2. Test Point Spacing**

The minimum center-to-center spacing between test points or adjacent drilled locations is as follows.

**Conventional Probe/Receptacle Spacing**

<b><u>Probe Combination</u></b>	<b><u>Minimum Spacing</u></b>
100 Mil Pogo ↔ 100 Mil Pogo	.083"
100 Mil Pogo ↔ 75 Mil Pogo	.076"
100 Mil Pogo ↔ 50 Mil Pogo	.068"
75 Mil Pogo ↔ 75 Mil Pogo	.068"
75 Mil Pogo ↔ 50 Mil Pogo	.061"
50 Mil Pogo ↔ 50 Mil Pogo	.050"

**EC-1 Probe Spacing**

<b><u>Probe Combination</u></b>	<b><u>Minimum Spacing</u></b>
100 Mil Pogo ↔ 100 Mil Pogo	.065"
100 Mil Pogo ↔ 75 Mil Pogo	.057"
100 Mil Pogo ↔ 50 Mil Pogo	.052"
75 Mil Pogo ↔ 75 Mil Pogo	.049"
75 Mil Pogo ↔ 50 Mil Pogo	.044"
50 Mil Pogo ↔ 50 Mil Pogo	.0395"

**3. Test targets should be at least .125" away from the edge of the PCB or "break away" areas.**

In vacuum fixtures, this region allows gaskets to meet evenly with the board surface and create a good vacuum seal. Mechanical board handlers may require additional clearance for conveyor rails.

**4. Test points should to be distributed evenly over the surface of the PCB.**

Areas of high probe density may cause the PCB to flex significantly, resulting in a loss of probe travel, poor probe contact with the test target and possible damage to the PCB (see also #5 below).

**5. PCBs should have a minimum thickness of .062" to assist in minimizing board flex.**

A board stress analysis should be considered to proactively identify areas of high stress or deflection, which can be addressed and corrected during fixture build. ECT offers both 2D and 3D board stress analysis capabilities.

**6. The preferred lead length is .062" or less.**

Avoid placing test points on excessively long leads. Additional machining may be required for long leads, which could result in additional plate deflection and compromising probe contact.

**7. Solder mask should not cover any test pads or vias.**

**8. A solder bump should exist on test pads that are recessed below the solder mask.**

Ideally, and if possible, solder paste should be applied to test pads at SMT screening to promote even and consistent solder bump formation.



**9. All vias should be closed.**

Excessive open vias and unfilled component holes cause air leaks inhibiting the vacuum seal. ECT can provide a mechanical hold down gate or lid to hold the board to the top plate while vacuum is actuated.

**10. Avoid placing nodes on SMT devices.**

This can cause damage to the device and provides minimal probe contact area.

**11. Preferred board manufacturing tolerances are as follows:**

- ✓ Tooling hole to pad/feature tolerance should be targeted at +/- .002".
- ✓ The diameter of the pad/feature should have a tolerance of +/- .002"
- ✓ The diameter of the tooling holes should have a tolerance of +.002"/-.000"

**12. Two tooling holes should be placed at opposite corners of the PCB.**

Tooling hole diameters should preferably be .125" and should be unplated. Tooling hole locations should be a minimum of .100" from the edge of the PCB. The use of diamond tooling pins should be considered to increase targeting accuracy.

**13. The preferred target size is .035".**

However, ECT offers a full line of fixture technologies to reliably contact smaller targets. Table (1) identifies the minimum recommended target size for various types of ECT fixtures based on a false failure rate of approximately 50 parts per million (ppm). Similarly, Figure (1) provides comparison of false failure rate versus target size for the various types of ECT fixtures.

Note: The results provided in Table (1) and Figure (1) are based on the following board manufacturing tolerances: +/- .004" on the location of the test target relative to the tooling hole, +/- .002" on the diameter of the test target and +/- .002" on the diameter of the tooling hole. ECT can perform tolerances studies to assess targeting accuracy for board manufacturing tolerances that differ from those listed above.



**Table (1)**

<b><u>ECT Fixture Type</u></b>	<b><u>Minimum Recommended Target Size</u></b>
<i>Conventional Fixture</i>	<i>.031"</i>
<i>Conventional Fixture With Receptacle Alignment Plate</i>	<i>.027"</i>
<i>Conventional Fixture With Large Guided Probe Holes</i>	<i>.025"</i>
<i>Conventional Fixture With Small Guided Probe Holes</i>	<i>.022"</i>
<i>Conventional Fixture With Small Guided Probe Holes and Diamond Tooling Pins</i>	<i>.020"</i>
<i>EC-1 Test Fixture</i>	<i>.018"</i>

**Figure (1)**  
**False Failure Rate vs. Target Size**

