

IP541

Test Probes for Bare and Loaded PCB Testing

The IP541 is an interchangeable probe designed for use in testing conventional PCBs.

SPECIFICATIONS

PROBE SERIES	IP541
Test Centers	.100 (2,54)
Mechanical	
Max. Plunger Travel	.160 (4,06)
Recom. Working Travel	.106 (2,69)
Mechanical Life (cycles)	>1,000,000
Spring Pressure	
Light:	initial 1.08 oz. (31g)
	@ working travel 3.5 oz. (99g)
Heavy:	initial 2.64 oz. (75g)
-1	@ working travel 6.5 oz. (184g)
Extra Heavy:	initial 4.09 oz. (116g)
-2	@ working travel 10.0 oz. (283g)
Materials & Finishes	
Plunger	Hardened Beryllium Copper, Gold plated over Nickel, except the K tip which is Tool Steel
Barrel	Work hardened Nickel Silver, Gold plated (I.D. & O.D.) over Nickel plate
Spring	Music Wire, Silver plated
Operating Range (typical)	-55°C to + 105°C
Electrical	
Current Rating (static conditions)	3 amps
Avg. Resistance (mOHMS)	50

RECEPTACLE SERIES	SR541 (Uses Insertion Tool #ARIT54)
Mounting Hole Size	.069 (1,75)
Suggested Drill Size	1,75 mm
Suggested Wire Gauge	22-30 AWG
Materials & Finishes	Work hardened Nickel Silver, Gold plated over Nickel plate
Terminations	Crimp, solder, wire wrap, round post

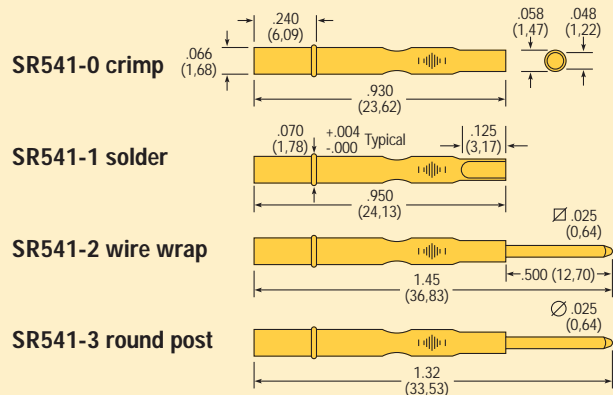
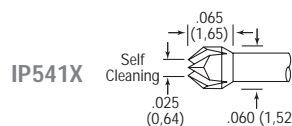
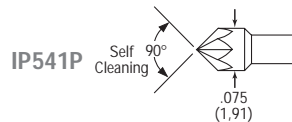
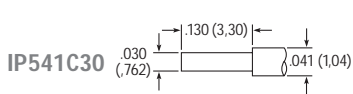
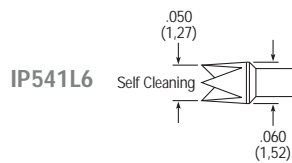
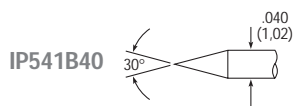
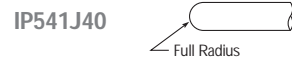
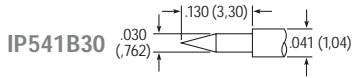
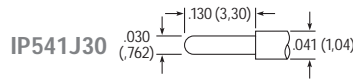
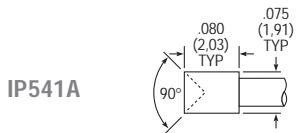
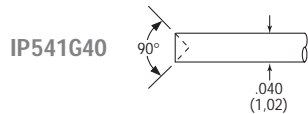
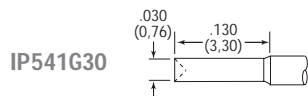
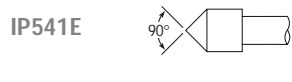
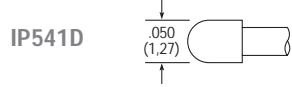
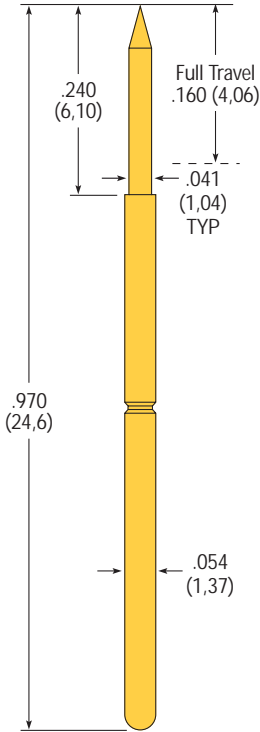

ORDERING INFORMATION: To order, specify tip style and spring pressure. Example: IP541A is an "A" tip with a light spring. For a heavy spring pressure, add -1 to the model number, i.e., IP541A-1.

Specifications subject to change without notice. Drawings not to scale. Optional tip styles, spring pressures, and materials available, contact factory for more information.

MT54

Test Probes for use in Everett Charles Test Equipment Bare PCB Testers

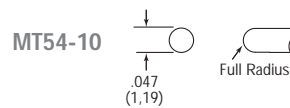
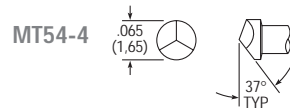
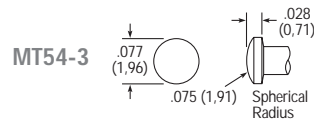
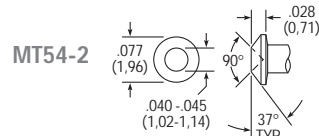
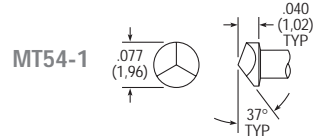
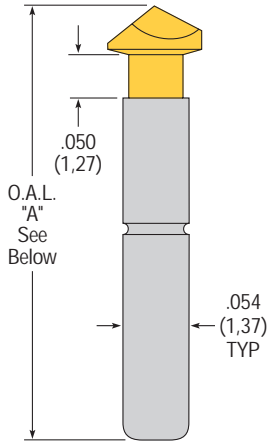

SPECIFICATIONS

PROBE SERIES	MT54
Test Centers	.100 (2,54)
Mechanical	
Max. Plunger Travel	.050 (1,27)
Recom. Working Travel	.050 (1,27)
Mechanical Life (cycles)	>1,000,000
Spring Pressure	
initial	1.1 oz. (31.2g)
@ working travel	3.8 oz. (108g)
Materials & Finishes	
Plunger	Hardened Beryllium Copper, Gold plated over Nickel plate
Barrel	Work hardened Nickel Silver, unplated
Spring	Stainless Steel, Silver plated
Operating Range (typical)	-55°C to + 150°C
Electrical	
Current Rating (static conditions)	3 amps
Avg. Resistance (mOHMS)	50

RECEPTACLE SERIES	MR54 (Uses Insertion Tool #MRT54-005)
Mounting Hole Size	.067/.069 (1,70/1,75)
Suggested Drill Size	1,75 mm
Suggested Wire Gauge	26-30 AWG
Materials & Finishes	Nickel Silver, unplated
Terminations	Wire wrap

MR54-2 wire wrap

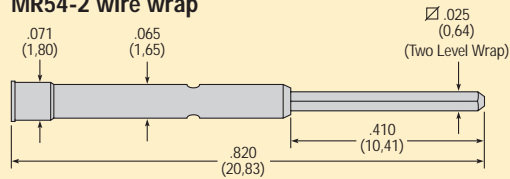

Hole Diameters to be Contacted:	Recommended Test Centers
MT54-1 up to .073 (1,85)	MT54-1, -2, -3, -4, -10 .100 (2,54)
MT54-2 lands and pads	
MT54-3 lands and pads	
MT54-4 up to .058 (1,47)	
MT54-10 lands and pads	

ORDERING INFORMATION: To order, specify model number, i.e., MT54-1.

Model No.	Dimension A
MT54-1, -4	.375 (9,53)
MT54-2, -3	.365 (9,27)
MT54-10	.363 (9,22)

Specifications subject to change without notice.
 Drawings not to scale.
 Optional tip styles, spring pressures, and materials available, contact factory for more information.

MT554

Test Probes for use in Everett Charles Technologies Bare PCB Test Fixtures

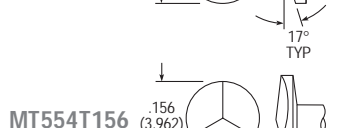
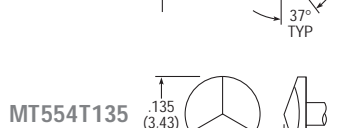
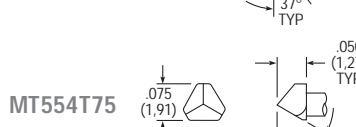
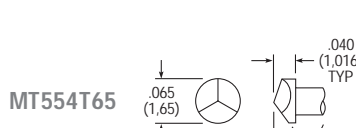
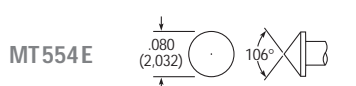
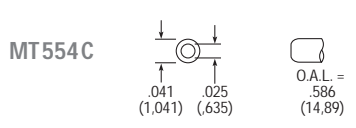
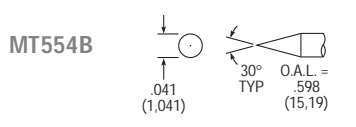
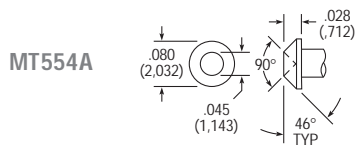
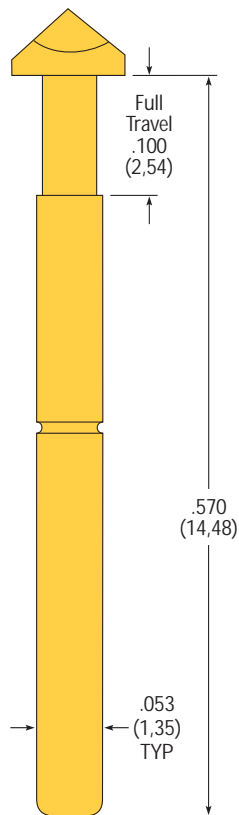

SPECIFICATIONS

PROBE SERIES	MT554
Test Centers	.100 (2,54), .156 (3,96), .187 (4,75)
Mechanical	
Max. Plunger Travel	.100 (2,54)
Recom. Working Travel	.075 (1,91)
Mechanical Life (cycles)	>2,000,000
Spring Pressure	
Light: initial	1.71 oz. (48g)
@ working travel	3.0 oz. (85g)
Heavy: initial	2.82 oz. (79,95g)
-1 @ working travel	5.0 (141g)
Materials & Finishes	
Plunger	Hardened Beryllium Copper, Gold plated over Nickel plate
Barrel	Work hardened Phosphor Bronze, Gold plated (I.D. & O.D.) over Nickel plate
Spring	Stainless Steel, Silver plated
Operating Range (typical)	-55°C to + 150°C
Electrical	
Current Rating (static conditions)	3 amps
Avg. Resistance (mOHMS)	35
RECEPTACLE SERIES	MR554 (Uses Insertion Tool #MRT554-005)
Mounting Hole Size	.067/.069 (1,70/1,75)
Suggested Drill Size	#51 or 1,75 mm
Suggested Wire Gauge	26-30 AWG
Materials & Finishes	Nickel Silver, unplated
Termination	Wire wrap

MR554-2 wire wrap

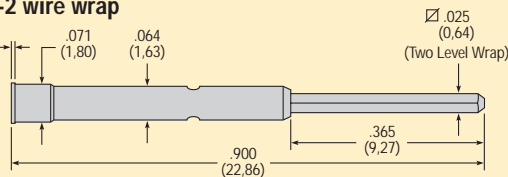

ORDERING INFORMATION: To order, specify tip style and spring pressure. Example: MT554C is a "C" tip with a light spring. For a heavy spring pressure, add -1 to the model number, i.e., MT554C-1.

<i>Hole Diameters to be Contacted:</i>	<i>Recommended Test Centers</i>	
MT554A lands and pads	MT554A, B, C, E, T65, T75, T80	.100 (2,54)
MT554B lands and pads	MT554T135	.156 (3,96)
MT554C lands and pads	MT554T156	.187 (4,75)
MT554E up to .073 (1,85)		
MT554T65 up to .058 (1,47)		
MT554T75 up to .070 (1,78)		
MT554T80 up to .073 (1,85)		
MT554T135 up to .125 (3,18)		
MT554T156 up to .150 (3,81)		

Specifications subject to change without notice.
 Drawings not to scale.
 Optional tip styles, spring pressures, and materials available, contact factory for more information.

IP80

Test Probes for General Purpose,
Cable and Harness, Burn-in,
Power Supply, and Connector Testing

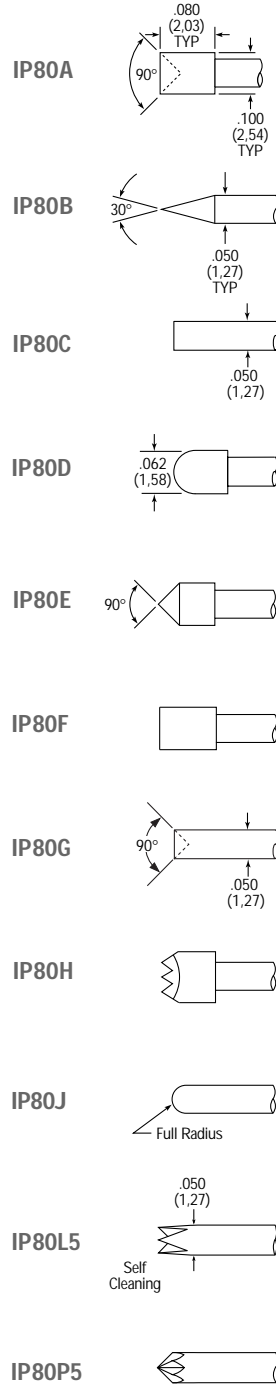
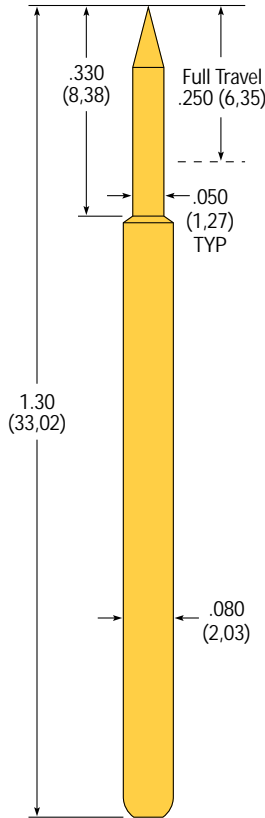

SPECIFICATIONS

PROBE SERIES	IP80
Test Centers	.125 (3,18)
Mechanical	
Max. Plunger Travel	.250 (6,35)
Recom. Working Travel	.166 (4,22)
Mechanical Life (cycles)	>1,000,000
Spring Pressure	
Light: initial	1.6 oz. (51g)
@ working travel	4.5 oz. (128g)
Heavy: initial	2.5 oz. (71g)
-1 @ working travel	6.5 oz. (184g)
Materials & Finishes	
Plunger	Hardened Beryllium Copper, Gold plated over Nickel plate
Barrel	Work hardened Nickel Silver, Gold plated over Nickel plate
Spring — light:	Beryllium Copper, Silver plated
— heavy:	Stainless Steel, Silver plated
Operating Range (typical)	Light -55°C to +105°C or Heavy -55°C to +150°C
Electrical	
Current Rating (static conditions)	6 amps
Avg. Resistance (mOHMS)	50

RECEPTACLE SERIES	SR80 (Uses Insertion Tool #T80-0)
Mounting Hole Size	.094/.096 (2,39/2,44)
Suggested Drill Size	#41 or 2,4 mm
Suggested Wire Gauge	22-26 AWG*
Materials & Finishes	Work hardened Nickel Silver, Gold plated over Nickel plate
Terminations	Crimp, solder, wire wrap

*22-26 AWG wire is recommended only for typical ATE applications.
Other applications may require a larger wire size. Contact factory for more information.

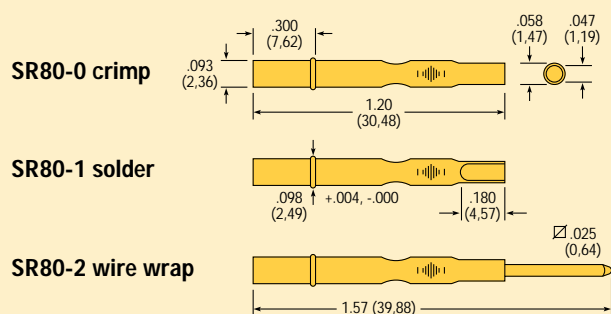

Specifications subject to change without notice.
Drawings not to scale.
Optional tip styles, spring pressures, and materials
available, contact factory for more information.

ORDERING INFORMATION: To order, specify tip style and spring pressure. Example: IP80A is an "A" tip with a light spring. For a heavy spring pressure, add -1 to the model number, i.e., IP80A-1.

IP93

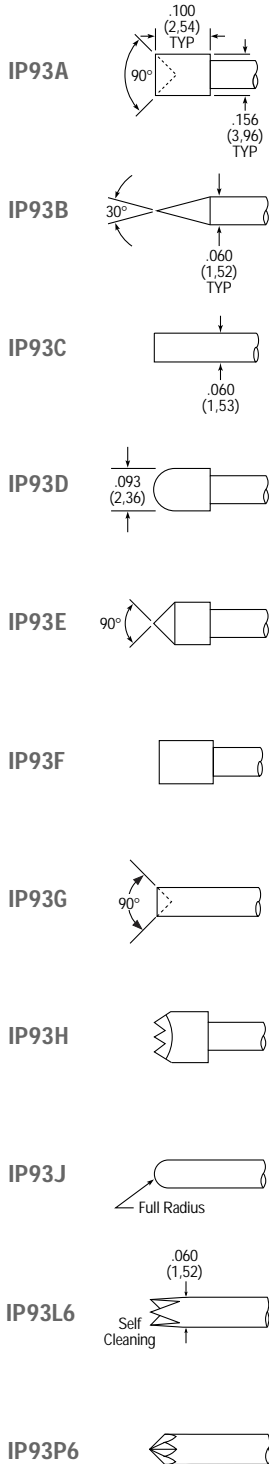
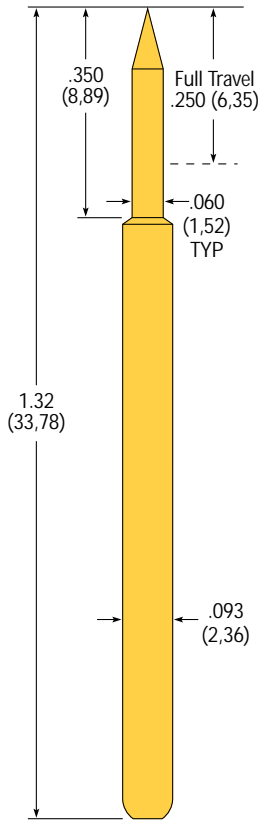

Test Probes for General Purpose, Cable and Harness, Burn-in, Power Supply, and Connector Testing

SPECIFICATIONS

PROBE SERIES	IP93
Test Centers	.187 (4,75)
Mechanical	
Max. Plunger Travel	.250 (6,35)
Recom. Working Travel	.166 (4,22)
Mechanical Life (cycles)	>1,000,000
Spring Pressure	
Light: initial	2.2 oz. (62g)
@ working travel	4.8 oz. (136g)
Heavy: initial	3.2 oz. (91g)
-1 @ working travel	6.9 oz. (196g)
Materials & Finishes	
Plunger	Hardened Beryllium Copper, Gold plated over Nickel
Barrel	Work hardened Nickel Silver, Gold plated over Nickel plate
Spring — light:	Beryllium Copper, Silver plated
— heavy:	Stainless Steel, Silver plated
Operating Range (typical)	Light -55°C to +105°C or Heavy -55°C to +150°C
Electrical	
Current Rating (static conditions)	7 amps
Avg. Resistance (mOHMS)	50

RECEPTACLE SERIES	SR93 (Uses Insertion Tool #T93-0)
Mounting Hole Size	.107/.109 (2,72/2,77)
Suggested Drill Size	2,75 mm
Suggested Wire Gauge	22-26 AWG*
Materials & Finishes	Work hardened Nickel Silver, Gold plated over Nickel plate
Terminations	Crimp, solder, wire wrap

* 22-26 AWG wire is recommended only for typical ATE applications. Other applications may require a larger wire size. Contact factory for more information.

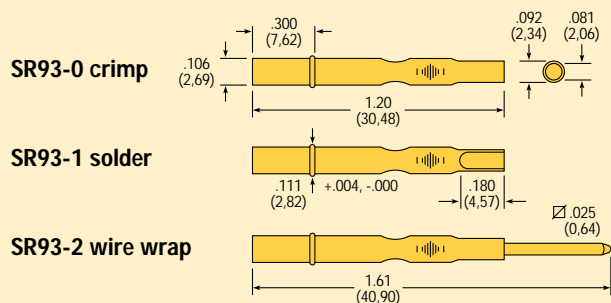

ORDERING INFORMATION: To order, specify tip style and spring pressure. Example: IP93A is an "A" tip with a light spring. For a heavy spring pressure, add -1 to the model number, i.e., IP93A-1.

Specifications subject to change without notice.
 Drawings not to scale.
 Optional tip styles, spring pressures, and materials available, contact factory for more information.

IP125

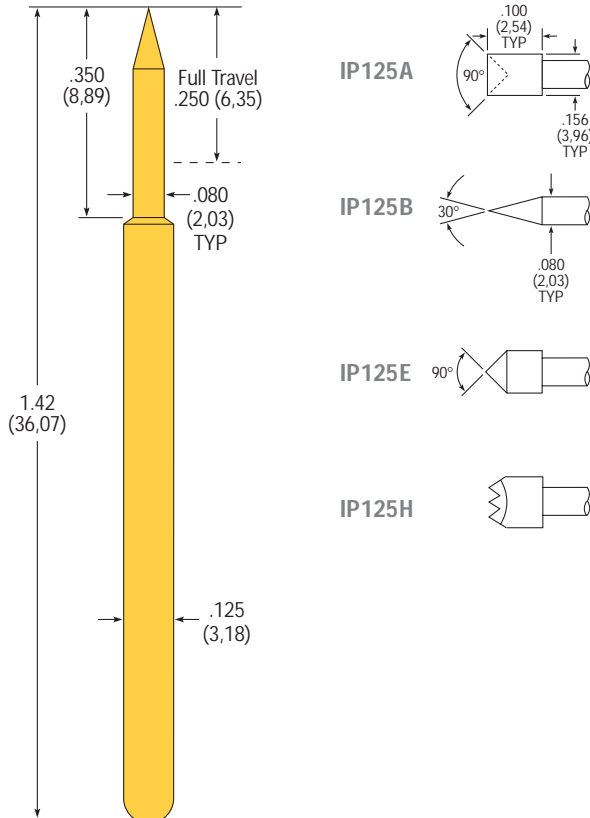

Test Probes for General Purpose, Cable and Harness, Burn-in, Power Supply, and Connector Testing

SPECIFICATIONS

PROBE SERIES	IP125
Test Centers	.187 (4,75)
Mechanical	
Max. Plunger Travel	.250 (6,35)
Recom. Working Travel	.166 (4,22)
Mechanical Life (cycles)	>1,000,000
Spring Pressure	
initial	6.1 oz. (173g)
@ working travel	16.0 oz. (454g)
Materials & Finishes	
Plunger	Hardened Beryllium Copper, Gold plated over Nickel plate
Barrel	Work hardened Nickel Silver, Gold plated over Nickel plate
Spring	Stainless Steel
Operating Range (typical)	-55°C to + 150°C
Electrical	
Current Rating (static conditions)	8 amps
Avg. Resistance (mOHMS)	50

RECEPTACLE SERIES	SR125 (Uses Insertion Tool #T125-0)
Mounting Hole Size	.141/.143 (3,58/3,63)
Suggested Drill Size	3,6 mm
Suggested Wire Gauge	22-26 AWG*
Materials & Finishes	Work hardened Nickel Silver, Gold plated over Nickel plate
Terminations	Crimp, solder, wire wrap

*22-26 AWG wire is recommended only for typical ATE applications. Other applications may require a larger wire size. Contact factory for more information.

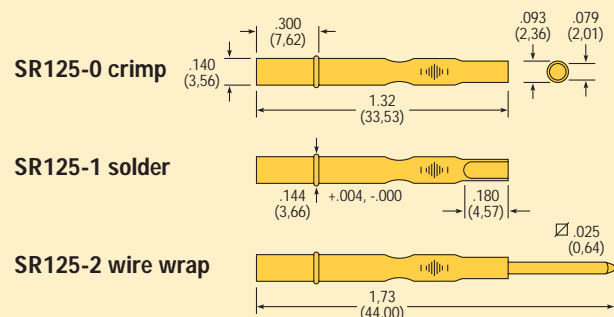

Specifications subject to change without notice.
Drawings not to scale.
Optional tip styles, spring pressures, and materials available, contact factory for more information.

ORDERING INFORMATION: To order, specify tip style. Example: IP125A is an "A" tip with a standard spring.

HC80

Test Probes for **HIGH CURRENT** and **HIGH TEMPERATURE** Applications

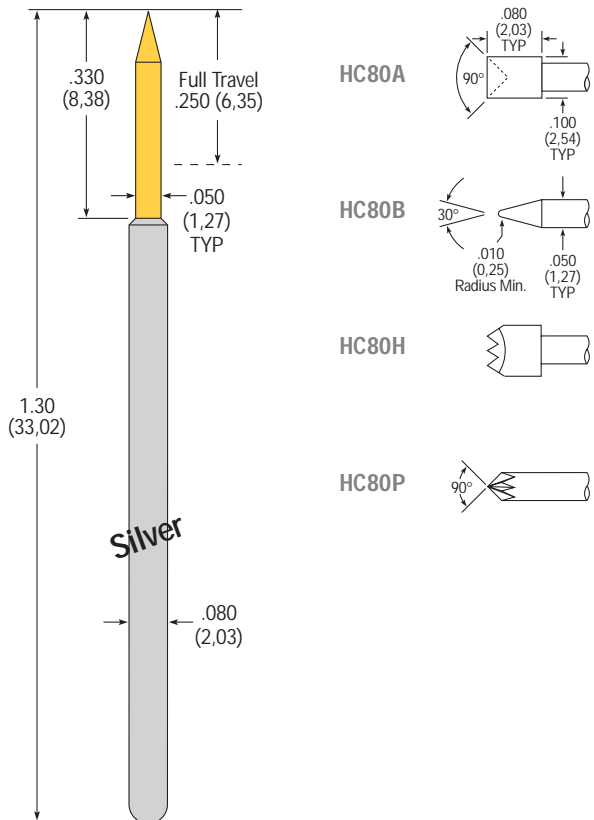

SPECIFICATIONS

PROBE SERIES	HC80
Test Centers	.125 (3,18)
Mechanical	
Max. Plunger Travel	.250 (6,35)
Recom. Working Travel	.166 (4,22)
Mechanical Life (cycles)	>250,000
Spring Pressure	
initial	1.54 oz. (44g)
@ working travel	4.5 oz. (128g)
Materials & Finishes	
Plunger	Hardened Beryllium Copper, Gold plated over Nickel plate
Barrel	Work hardened Nickel Silver, Silver plated (I.D. & O.D.) over Nickel Silver
Spring	Stainless Steel, Silver plated
Operating Range (typical)	-55°C to + 150°C
Electrical	
Current Rating (static conditions)	15 amps (continuous current ambient temp.)
Avg. Resistance (mOHMS)	25

RECEPTACLE SERIES	SR80 (Uses Insertion Tool #T80-0)
Mounting Hole Size	.094/.096 (2,39/2,44)
Suggested Drill Size	#41 or 2,4 mm
Suggested Wire Gauge	22-26 AWG*
Materials & Finishes	Work hardened Nickel Silver, Gold plated over Nickel plate
Terminations	Crimp, solder, wire wrap

*22-26 AWG wire is recommended only for typical ATE applications. Other applications may require a larger wire size. Contact factory for more information.

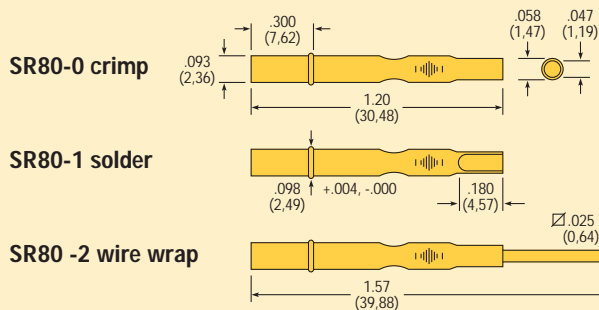

ORDERING INFORMATION: To order, specify tip style. Example: HC80A is an "A" tip with a standard spring pressure.

Specifications subject to change without notice.
 Drawings not to scale.
 Optional tip styles, spring pressures, and materials available, contact factory for more information.

HC93

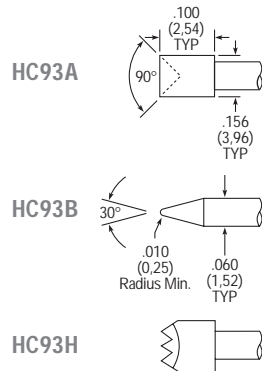
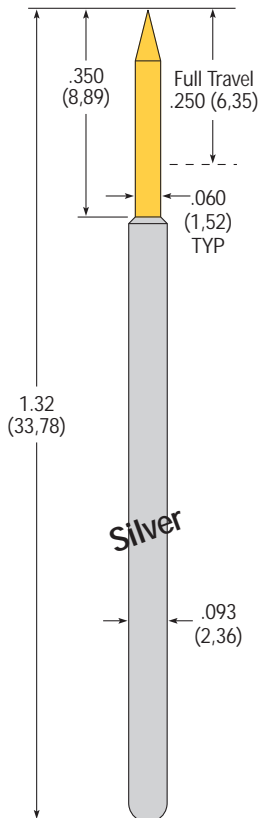

Test Probes for *HIGH CURRENT* and *HIGH TEMPERATURE* Applications

SPECIFICATIONS

PROBE SERIES	HC93
Test Centers	.187 (4,75)
Mechanical	
Max. Plunger Travel	.250 (6,35)
Recom. Working Travel	.166 (4,22)
Mechanical Life (cycles)	>250,000
Spring Pressure	
initial	0.86 oz. (24g)
@ working travel	4.8 oz. (136g)
Materials & Finishes	
Plunger	Hardened Beryllium Copper, Gold plated over Nickel plate
Barrel	Work hardened Nickel Silver, Silver plated (I.D. & O.D.) over Nickel Silver
Spring	Stainless Steel, Silver plated
Operating Range (typical)	-55°C to + 150°C
Electrical	
Current Rating (static conditions)	25 amps (continuous current ambient temp.)
Avg. Resistance (mOHMS)	25

RECEPTACLE SERIES	SR93 (Uses Insertion Tool #T93-0)
Mounting Hole Size	.107/.109 (2,72/2,77)
Suggested Drill Size	2,75 mm
Suggested Wire Gauge	22-26 AWG*
Materials & Finishes	Work hardened Nickel Silver, Gold plated over Nickel plate
Terminations	Crimp, solder, wire wrap

*22-26 AWG wire is recommended only for typical ATE applications. Other applications may require a larger wire size. Contact factory for more information.

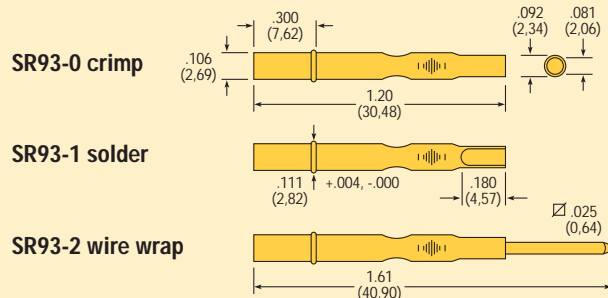

Specifications subject to change without notice.
 Drawings not to scale.
 Optional tip styles, spring pressures, and materials available, contact factory for more information.

ORDERING INFORMATION: To order, specify tip style. Example: HC93A is an "A" tip with a standard spring.

HC125

Test Probes for **HIGH CURRENT** and **HIGH TEMPERATURE** Applications

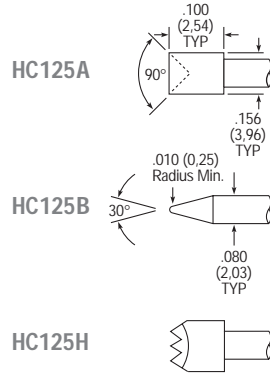
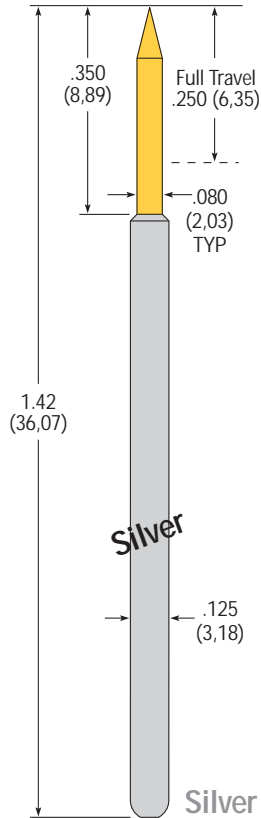

SPECIFICATIONS

PROBE SERIES	HC125
Test Centers	.187 (4,75)
Mechanical	
Max. Plunger Travel	.250 (6,35)
Recom. Working Travel	.166 (4,22)
Mechanical Life (cycles)	>250,000
Spring Pressure	
initial	3.76 oz. (107g)
@ working travel	16.0 oz. (456g)
Materials & Finishes	
Plunger	Hardened Beryllium Copper, Gold plated over Nickel plate
Barrel	Work hardened Nickel Silver, Silver plated (I.D. & O.D.) over Nickel Silver
Spring	Stainless Steel, Silver plated
Operating Range (typical)	-55°C to + 150°C
Electrical	
Current Rating (static conditions)	35 amps (continuous current ambient temp.)
Avg. Resistance (mOHMS)	25

RECEPTACLE SERIES	SR125 (Uses Insertion Tool #T125-0)
Mounting Hole Size	.141/.143 (3,58/3,63)
Suggested Drill Size	3,6 mm
Suggested Wire Gauge	22-26 AWG*
Materials & Finishes	Work hardened Nickel Silver, Gold plated over Nickel plate
Terminations	Crimp, solder, wire wrap

*22-26 AWG wire is recommended only for typical ATE applications. Other applications may require a larger wire size. Contact factory for more information.

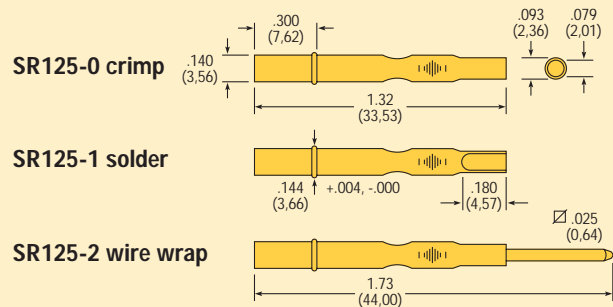

ORDERING INFORMATION: To order, specify tip style. Example: HC125A is an "A" tip with a standard spring pressure.

Specifications subject to change without notice. Drawings not to scale. Optional tip styles, spring pressures, and materials available, contact factory for more information.

FRP-25T GSP-2B

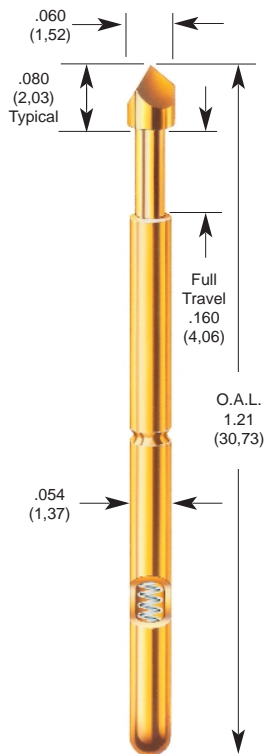

For Factron Series 300/700
FRP-25T

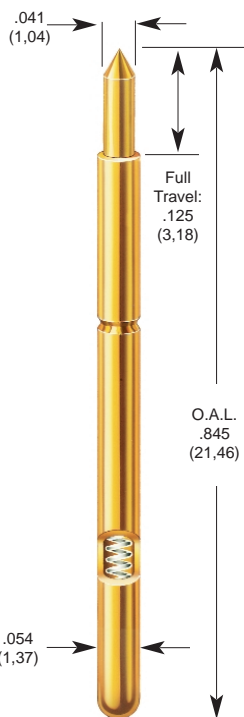

For GenRad 227/82/73
GSP-2B

Note: The GSP-2BP is designed for use in receptacles without detents.

ATE Receiver Probes

SPECIFICATIONS

PROBE SERIES	FRP-25T	GSP-2B
Application:	The FRP-25T is designed for use in Schlumberger (Factron) tester interfaces	The GSP-2B is designed for use in GenRad tester interfaces
Mechanical Full Travel:	.160 (4,06)	.125 (3,18)
Operating Temperature:	-55°C to +105°C Consult factory for other temperature requirements, and applications below -40°C	-55°C to + 130°C
Electrical (Static Conditions) Current Rating: Maximum continuous current, non-inductive at working travel	5 amps	5 amps
Probe Resistance:	35 mΩ With a standard deviation of <5 mΩ @ 25 mA test current	35 mΩ
Materials and Finishes Plunger:	Heat-treated beryllium copper, gold plated over hard nickel	Heat-treated beryllium copper, gold plated over hard nickel
Barrel:	Work-hardened phosphor bronze, gold plated over hard nickel	Work-hardened nickel silver, gold plated (I.D. and O.D.) over hard nickel
Spring:	Music wire, gold plated	Beryllium copper, silver plated

RECEPTACLE SPECIFICATIONS (Uses Insertion Tool #ARIT54)

Materials and Finishes	FRP-25T	GSP-2B
Housing:	Work-hardened nickel silver, gold plated over hard nickel	Work-hardened nickel silver, gold plated over hard nickel
Round Post:	Phosphor bronze, gold plated	Phosphor bronze, gold plated
Square Post:	Phosphor bronze, gold plated	Phosphor bronze, gold plated

SPRING FORCE +/- 20% IN OZ. (GRAMS)

Spring Type	Preload	3/4 Travel
FRP-25T as shown	.92 (26)	4.0 (113)
GSP-2B as shown	2.0 (57)	4.5 (128)

Optional spring forces and materials are available.

W

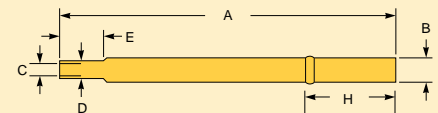

W-1



W-2 \square W-3 \circ

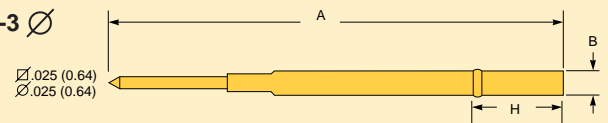

Y

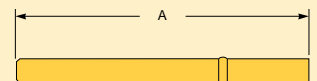

Receptacle Dimensions

	A	B	C	D	E
SPR-25W	1.15(29,21)	.066(1,68)	.048(1,22)	.058(1,47)	.180(4,57)
SPR-25W-1	1.19(30,23)	.066(1,68)	.048(1,22)	.058(1,47)	.180(4,57)
SPR-25W-2	1.69(42,93)	.066(1,68)	Square Post = .025(0,064)		
SPR-25W-3	1.56(39,62)	.066(1,68)	Round Post = .025(0,064) DIA.		
SPR-2W	.930(23,62)	.066(1,68)	.048(1,22)	.058(1,47)	.20(5,08)
SPR-2W-1	.950(24,13)	.066(1,68)	.048(1,22)	.058(1,47)	.20(5,08)
SPR-2W-2	1.45(36,83)	.066(1,68)	Square Post = .025(0,064)		
SPR-2W-3	1.32(33,53)	.066(1,68)	Round Post = .025(0,064) DIA.		
SPR-2Y	.735(18,67)	.066(1,68)			

SPR-25 and SPR-2 Series press ring diameter is typically .070 (1,78)
H dimension SPR-25 Series = .300 (7,62) and SPR-2 Series = .240 (6,09)

SIP-90 GPP-95-2

ATE Interface Pins

GPP-95-2

Materials: Brass, gold plated
 Mounting Hole Size: .085 (2,15)
 Applications: Designed for use in original GenRad interface boards.

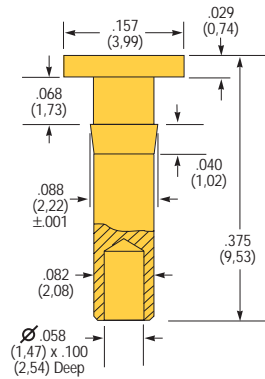

SIP-90-2

Materials: Brass, gold plated
 Mounting Hole Size: .055 (1,40)
 Applications: Designed for use in original GenRad interface blocks.

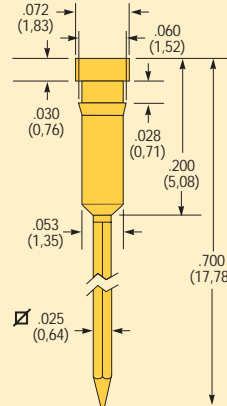

SIP-90-3

Materials: Brass, gold plated
 Mounting Hole Size: .055 (1,40)
 Applications: Designed for use in original Zehntel interface panels.

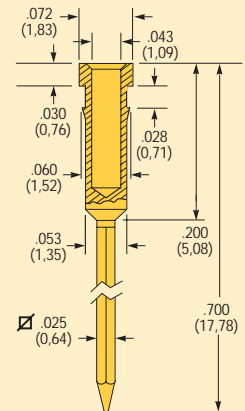

SIP-90-4

Materials: Brass, gold plated
 Mounting Hole Size: .055 (1,40)
 Applications: Designed for use in original Factorion interface panels. SIP-90-4 replaces SIP-90-1.

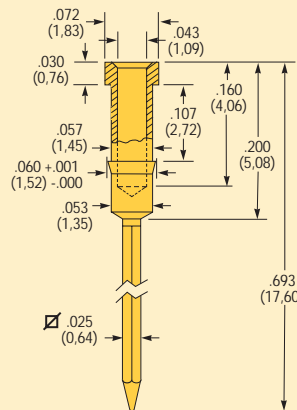

SIP-90-5

Materials: Brass, gold plated
 Mounting Hole Size: .057 (1,45)
 Applications: General interconnect.

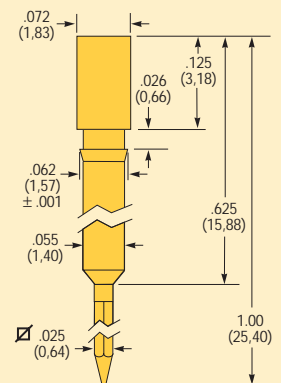

SIP-90-6

Materials: Brass, gold plated
 Mounting Hole Size: .057 (1,45)
 Applications: General interconnect.

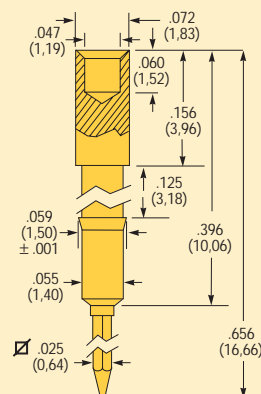

SIP-90-7

Materials: Brass, gold plated
 Mounting Hole Size: .0595 (1,51)
 Applications: General interconnect.

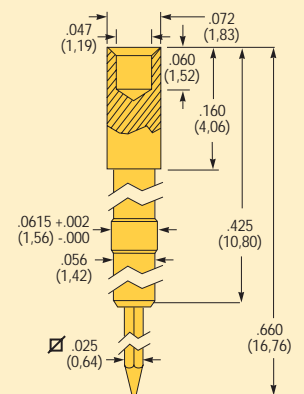

High Performance Contact Solutions for Semiconductor Test Packages

High density packages (BGA, CSPs, μ BGAs) continue their expanding popularity in today's modern PCBs. Increasing rise times and increasing signal density affect all areas of interconnection technology.

Test probes and Pogo[®] contacts continue to demonstrate their flexibility in newer demanding test/contact areas. Ostby Barton has years of experience in designing and producing high performance contacts needed in applications for: higher frequency test, low resistance measurements, high cycle life requirements, new solder technology processes, and other test connections (memory test, burn-in, handler apps, etc.)

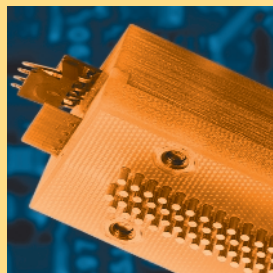
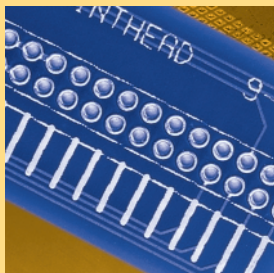
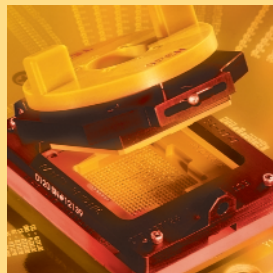
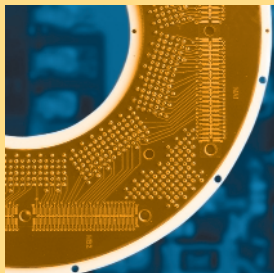

CSP4 CSP8 CSP5 CSP1-1.27

Double Ended Performance Pogo® Contacts for BGA, CSP, LGA and PGA Test Applications

ECT offers a wide variety of Double-Ended Pogos® on pitches ranging from .4 mm to 1.27 mm. Various length options also provides drop-in replacement capability for most competitor probes.

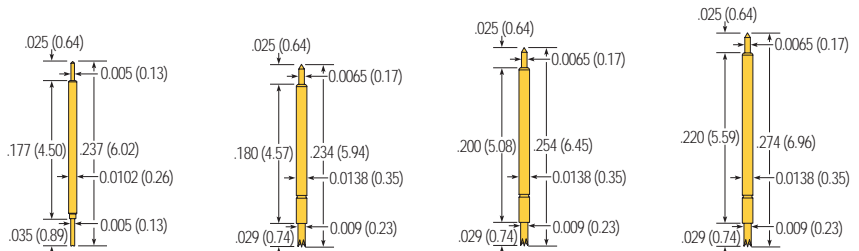

Specifications	CSP4	CSP5-18	CSP5-20	CSP5-22
Mechanical				
Pitch:	.4mm	.5mm	.5mm	.5mm
Recommended Mounting Centers:	.016 (0,40)	.020 (0,50)	.020 (0,50)	.020 (0,50)
Full Travel:	.025 (0,64)	.025 (0,64)	.025 (0,64)	.025 (0,64)
Recommended Travel:	.020 (0,51)	.020 (0,51)	.020 (0,51)	.020 (0,51)
Test Height:	.217 (5,51)	.214 (5,44)	.234 (5,94)	.254 (6,45)
Spring Force:	.85 (24,1g)	.7oz (19,8g)	.7oz (19,8g)	1.0oz (28,4g)
Overall Length:	.237 (6,02)	.234 (5,94)	.254 (6,45)	.274 (6,96)
Mechanical Life:	250,000 cycles	500,000 cycles	500,000 cycles	500,000 cycles
Materials and Finishes				
Plunger End (long extension)	BeCu or Steel	BeCu or Steel	BeCu or Steel	BeCu or Steel
Terminal End (short Extension)	BeCu or Steel	BeCu or Steel	BeCu or Steel	BeCu or Steel
Barrel:	Hard Gold over Nickel Phosphor Bronze Hard Gold over Nickel	Hard Gold over Nickel Phosphor Bronze Hard Gold over Nickel	Hard Gold over Nickel Phosphor Bronze Hard Gold over Nickel	Hard Gold over Nickel Phosphor Bronze Hard Gold over Nickel
Spring:	Music Wire/Gold Plate	Steel Alloy/Gold Plate	Steel Alloy/Gold Plate	Music Wire/Gold Plate
Environmental				
Maximum Operating Temperature:	105°C	155°C	155°C	105°C
Electrical				
Average DC Resistance:**	<100mΩ	<100mΩ	<100mΩ	<100mΩ
Current Capacity:	2A	2A	2A	2A
Self Inductance (Ls):	1.71nH	1.5nH*	1.65nH*	1.79nH
Capacitance (Cc):	.58pF	.63pF*	.69pF*	.75pF
Bandwidth @ -1dB:	6.8GHz	8.13GHz*	7.4GHz*	6.8GHz

B-TIP PLUNGER-DUT (ALL CSP PROBES)

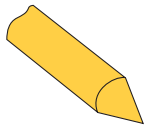

L-TIP PLUNGER-DUT (ALL CSP PROBES)

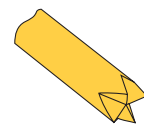

ORDERING INFORMATION

CSP5

Example: CSP5-20LCBC

Model Number: CSP5-20L C B C

Barrel Length:

- 18 = .180
- 20 = .200
- 22 = .220

Plunger Tip Style:

- B, L

Plunger Material:

- C = BeCu
- S = Steel

Terminal Tip Style:

- B, L

Terminal Material:

- C = BeCu
- S = Steel

CSP8

Example: CSP8-25BSBS

Model Number: CSP8-25B S B S

Barrel Length:

- 15 = .150
- 20 = .200
- 25 = .250

Plunger Tip Style:

- B, L

Plunger Material:

- C = BeCu
- S = Steel

Terminal Tip Style:

- B, L

Terminal Material:

- C = BeCu
- S = Steel

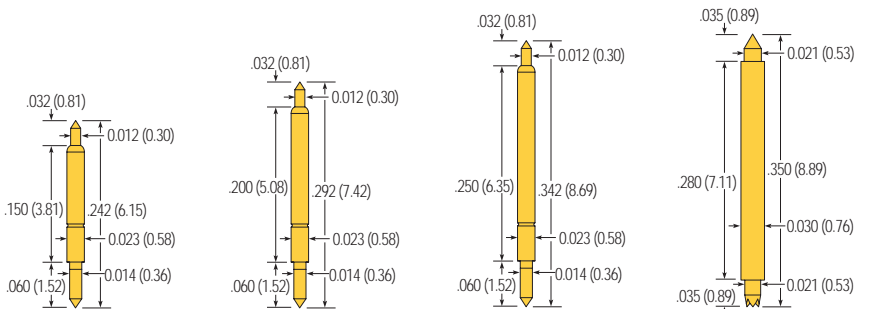

Specifications	CSP8-15	CSP8-20	CSP8-25	CSP1-1.27
Mechanical				
Pitch:	.8mm	.8mm	.8mm	1.0 - 1.27mm
Recommended Mounting Centers:	.0315 (0,80)	.0315 (0,80)	.0315 (0,80)	.039 (1,0) / .050 (1,27)
Full Travel:	.040 (1,02)	.040 (1,02)	.040 (1,02)	.040 (1,02)
Recommended Travel:	.030 (0,76)	.030 (0,76)	.030 (0,76)	.035 (0,89)
Test Height:	.212 (5,38)	.262 (6,65)	.312 (7,92)	.315 (8,0)
Spring Force:	1.1oz (31,2g)	1.1oz (31,2g)	1.1oz (31,2g)	2.0oz (56,7g)
Overall Length:	.242 (6,15)	.292 (7,42)	.342 (8,69)	.350 (8,89)
Mechanical Life:	500,000 cycles	500,000 cycles	500,000 cycles	500,000 cycles
Materials and Finishes				
Plunger End (long extension)	BeCu or Steel	BeCu or Steel	BeCu or Steel	BeCu
Terminal End (short Extension)	BeCu or Steel	BeCu or Steel	BeCu or Steel	BeCu
Barrel:	Hard Gold over Nickel Phosphor Bronze Hard Gold over Nickel	Hard Gold over Nickel Phosphor Bronze Hard Gold over Nickel	Hard Gold over Nickel Phosphor Bronze Hard Gold over Nickel	Hard Gold over Nickel Phosphor Bronze Hard Gold over Nickel
Spring:	Steel Alloy/Gold Plate	Steel Alloy/Gold Plate	Steel Alloy/Gold Plate	Steel Alloy/Gold Plate
Environmental				
Maximum Operating Temperature:	155°C	155°C	155°C	155°C
Electrical				
Average DC Resistance:**	<100mΩ	<100mΩ	<100mΩ	<50mΩ
Current Capacity:	3A	3A	3A	5A
Self Inductance (Ls):	1.23nH*	1.52nH*	1.81nH	3.1nH
Capacitance (Cc):	.65pF*	.81pF*	.96pF	.95pF
Bandwidth @ -1dB:	9.23GHz*	7.45GHz*	5.25GHz	3.8GHz

Consult factory for availability.

*Estimated

**DC Resistance measured contacting a clean gold plated surface on both probe tips.

BGA/PGA, LGA Applications

SOIC Package Test Contacts

The following assortment of Pogo contacts has been carefully selected from numerous successful solutions for high performance testing. Many have been used in test sockets for high speed CPU and memory BGA assemblies.

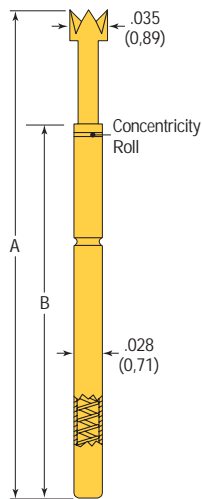

BGA & PGA Crown Head

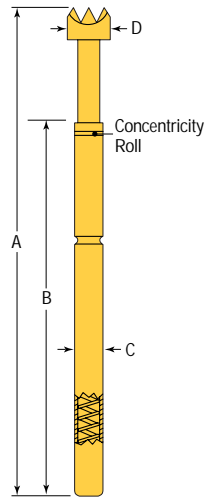

BGA & PGA Serrated Head

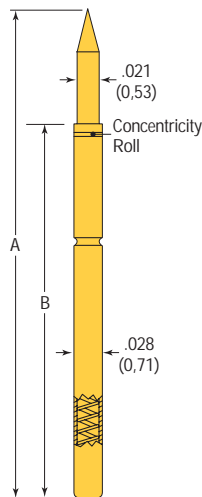

LGA Spear Point

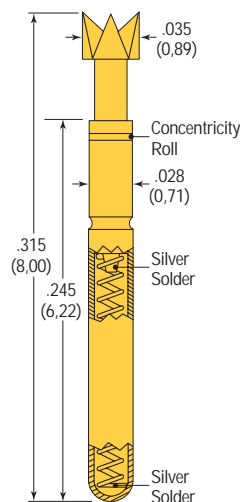

BGA

RECEPTACLES

BGR28-3

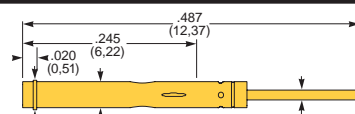

BGR28-DE

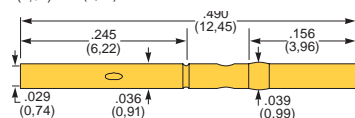

BGR28-S

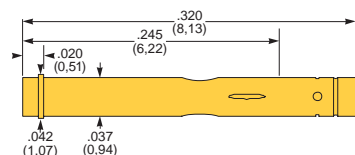

Consult factory for availability.

SPECIFICATIONS

BGA & PGA Crown Heads

Model Number	BGP28BL35ST	BGP28SL35ST	BGP28BL35LT	BGP28SL35LT
A: Overall Length	.315 (8,00)	.315 (8,00)	.470 (11,94)	.470 (11,94)
B: Barrel Length	.245 (6,22)	.245 (6,22)	.360 (9,14)	.360 (9,14)
Recommended Working Travel	.040 (1,02)	.040 (1,02)	.053 (1,35)	.053 (1,35)
Full Travel	.040 (1,02)	.040 (1,02)	.080 (2,03)	.080 (2,03)
Spring Pressure at Working Travel	2.0 OZ (57g)	2.0 OZ (57g)	2.0 OZ (57g)	1.6 OZ (45g)
Spring Material	BEUC	302 S.S.	BEUC	302 S.S.
Test Centers	.050 (1,27)			
Mechanical Life (Cycles)	> 25,000			
Electrical Current Rating (Static Conditions)	2-3 AMPS			
Electrical Average Resistance (mOHMS)	<50			

BGA & PGA Serrated Heads

Model Number	BGP28BHST	BGP28SHST	BGP28MHST	BGP28BHST
A: Overall Length	.295 (7,49)	.315 (8,00)	.470 (11,94)	.580 (14,73)
B: Barrel Length	.225 (5,72)	.245 (6,22)	.360 (9,14)	.470 (11,94)
C: Body Diameter	.028 (0,71)	.028 (0,71)	.028 (0,71)	.027 (0,69)
D: Head Diameter	.040 (1,02)	.040 (1,02)	.040 (1,02)	.035 (0,89)
Recommended Working Travel	.040 (1,02)	.040 (1,02)	.053 (1,35)	.075 (1,90)
Full Travel	.040 (1,02)	.040 (1,02)	.080 (2,03)	.075 (1,90)
Spring Pressure at Working Travel	2.0 OZ (57g)	2.0 OZ (57g)	2.1 OZ (60g)	2.5 OZ (71g)
Spring Material	BEUC	302 S.S.	Music Wire	BEUC
Test Centers	.050 (1,27)			
Mechanical Life (Cycles)	> 25,000			
Electrical Current Rating (Static Conditions)	2-3 AMPS			
Electrical Average Resistance (mOHMS)	<50			

LGA Spear Points

Model Number	LGP28BBST	LGP28SBST	LGP28BBLT	LGP28SBLT
A: Overall Length	.315 (8,00)	.315 (8,00)	.470 (11,94)	.470 (11,94)
B: Barrel Length	.245 (6,22)	.245 (6,22)	.360 (9,14)	.360 (9,14)
Recommended Working Travel	.040 (1,02)	.040 (1,02)	.053 (1,35)	.053 (1,35)
Full Travel	.040 (1,02)	.040 (1,02)	.080 (2,03)	.080 (2,03)
Spring Pressure at Working Travel	2.0 OZ (57g)	2.0 OZ (57g)	2.0 OZ (57g)	2.0 OZ (57g)
Spring Material	BEUC	302 S.S.	BEUC	302 S.S.
Test Centers	.050 (1,27)			
Mechanical Life (Cycles)	> 25,000			
Electrical Current Rating (Static Conditions)	2-3 AMPS			
Electrical Average Resistance (mOHMS)	<50			

This series can also be used as a "Ground Probe"

BGA

Model Number	BGP28BL35ST-S
Test Centers	.050 (1,27)
Recommended Working Travel	.040 (1,02)
Full Travel	.040 (1,02)
Spring Pressure at Working Travel	2.0 OZ (57g)
Mechanical Life (Cycles)	> 25,000
Electrical Current Rating (Static Conditions)	2-3 Amps
Electrical Average Resistance (mOHMS)	< 50

Cyclo Soldered Construction

BGA/PGA Various

Special Contacts, Handler Interface Contacts, Double-Ended Fine Pitch Contacts

For Discrete IC testing, BGA and PGA Contacts, and DUT Ring, for applications that require high performance interconnections.

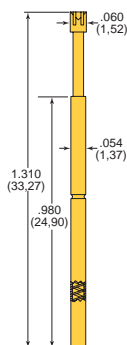

PGA OR OTHER PIN APPLICATIONS

Model Number	PIN54SG-1
Test Centers	.100 (2,54)
Recommended Working Travel	.166 (4,22)
Full Travel	.250 (6,35)
Spring Pressure At Working Travel	6.3 OZ (179g)
Mechanical Life (Cycles)	> 25,000
Electrical Current Rating (Static Conditions)	2-3 Amps
Electrical Average Resistance (mOHMS)	< 50
Uses Standard SR54 Receptacles	

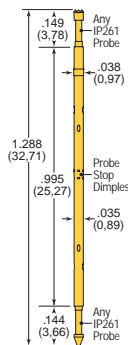

HANDLER INTERFACE PROBE / DOUBLE ENDER*

Model Number	DER28-IP261
Test Centers	.050 (1,27)
Recommended Working Travel (Each End)	.067 (1,70)
Full Travel (Each End)	.100 (2,54)
Spring Pressure At Working Travel	2.8 OZ (79g)
Mechanical Life (Cycles)	> 1,000,000
Electrical Current Rating (Static Conditions)	3 Amps
Electrical Average Resistance (mOHMS)	< 35
Recommended Hole Size	.036 Dia (#64 Drill)
*Probe not included, unless specified.	

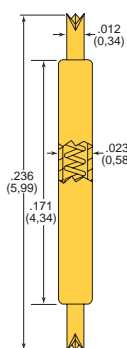

DOUBLE ENDED FINE PITCH CONTACTS

Model Number	BGP23U12-DE
Test Centers	.030 (0,762)
Recommended Working Travel	.030 (0,76)
Full Travel	.040 (1,02)
Spring Pressure At Working Travel	1.5 OZ (43g)
Mechanical Life (Cycles)	> 25,000
Electrical Current Rating (Static Conditions)	2-3 Amps
Electrical Average Resistance (mOHMS)	< 50

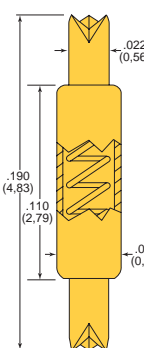

Model Number	BGP36U22-DE
Test Centers	.050 (1,27)
Recommended Working Travel	.030 (0,76)
Full Travel	.040 (1,02)
Spring Pressure At Working Travel	1.5 OZ (43g)
Mechanical Life (Cycles)	> 25,000
Electrical Current Rating (Static Conditions)	2-3 Amps
Electrical Average Resistance (mOHMS)	< 50
Large Plunger Dia Enables Contact To Offset Ball Locations	

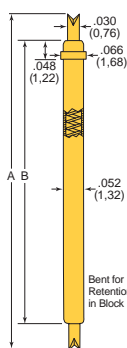

	BGP52L30-DE-SV	BGP52L30-DE-LV
A: Overall Length	.576 (14,63)	.876 (22,25)
B: Barrel Length	.436 (11,07)	.736 (18,69)
Recommended Working Travel	.093 (2,36)	.093 (2,36)
Full Travel	.140 (3,56)	.140 (3,56)
Spring Pressure at Working Travel	1.9 OZ (54g)	2.0 OZ (57g)
Test Centers	.100 (2,54)	.100 (2,54)
Mechanical Life (Cycles)	> 25,000	> 25,000
Electrical Current Rating (Static Conditions)	2-3 Amps	2-3 Amps
Electrical Average Resistance (mOHMS)	< 50	< 50

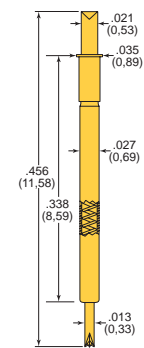

Model Number	BGP27G21-DE
Test Centers	.050 (1,27)
Recommended Working Travel	.040 (1,02)
Full Travel	.080 (2,03)
Spring Pressure At Working Travel	1.4 OZ (40g)
Mechanical Life (Cycles)	> 25,000
Electrical Current Rating (Static Conditions)	2-3 Amps
Electrical Average Resistance (mOHMS)	< 50

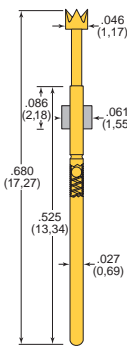

Model Number	BGP27L46-INS
Test Centers	.050 (1,27)
Recommended Working Travel	.100 (2,54)
Full Travel	.115 (2,92)
Spring Pressure At Working Travel	2.9 OZ (82g)
Mechanical Life (Cycles)	> 25,000
Electrical Current Rating (Static Conditions)	2-3 Amps
Electrical Average Resistance (mOHMS)	< 50
Insulated Ring:	Ultem

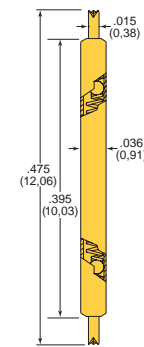

Model Number	BGP36U15-DE
Test Centers	.050 (1,27)
Recommended Working Travel	.060 (15,24)
Full Travel	.080 (2,03)
Spring Pressure At Working Travel	2.5 OZ (71g)
Mechanical Life (Cycles)	> 25,000
Electrical Current Rating (Static Conditions)	2-3 Amps
Electrical Average Resistance (mOHMS)	< 50
Double Bias Ball	

Consult factory for availability.

Tools



Crimp Pliers

Model #900*

Interchangeable Crimp Plier Locators

Model #	Receptacle Series
CL20	SR20
CL261	SR261
CL27	SR27
CL31	HPR72
CL40	SR40
CL54	SR54
CL541	SR541
CL80	SR80

* Operating instructions are included with each plier ordered.

Specifications subject to change without notice. Drawings not to scale. Optional tip styles, spring pressures, and materials available, contact factory for more information.



Receptacle Insertion Tools

Model #	Mounting Height	Receptacle Series
T20-0	Flush	SR20
T261-0	Flush	SR261
T27-0	Flush	SR27
AT31	Flush-.285	HPR72 HPR72W
ARIT40	Flush-.125	SR40
ARIT40	.160-.220	LR40 LTR-1W
ARIT54	Flush-.125"	SR541
ARIT54	Flush-.220"	SR54 SPR25W
T80-0	Flush	SR80
T93-0	Flush	SR93
T125-0	Flush	SR125
MRT54-005	.005 (0,13)	MR54
MRT554-005	.005 (0,13)	MR554

Adjustable Tool (ARIT) Instructions

1. Loosen set screws.
2. Rotate thimble to desired receptacle mounting height.
3. Lock both set screws.

Miscellaneous Insertion Tools

Model #	Description
FIT-1	Quick Connect™ insertion tool for SR28-4, SR31-4
PIT-261	Probe insertion tool for IP261 Series
PIE-54	Probe insertion and extraction tool for 100 mil center headed test probes



Maintenance Brushes

Model #	Description
MB-1	Brass bristle brush (4-1/4" x 2-1/2")
MB-2	4 row brass brush (3-1/4" x 1-1/8")
MB-3	Nylon brush (6-1/4")



Receptacle Installation

The receptacle is inserted into the drilled hole and tapped into place using a plastic mallet and a receptacle insertion tool. Several "taps" (3-5) with the mallet is recommended to provide maximum receptacle retention. Epoxy is not required. The receptacle is held in place by the press ring, which collapses into the hole during insertion, forming a tight fit.

While some insertion tools are designed to mount the receptacles flush with the probe plate, the ARIT series (Adjustable Tool) allows various mounting heights as required by the test fixture manufacturer. For instance, many users of the Pogo-25 long stroke series typically mount them .220" (5,59 mm) above the surface. The press ring is positioned for maximum retention in probe plates that are 3/8 inch thick or more. If the probe plate is too thin, the receptacle may fall through during insertion. In this case you can drill a smaller hole and use the press ring as a stop. However, you will need to secure receptacle with epoxy.

Once the receptacle is installed, insert the probe until the top of the probe barrel is flush with the top of the receptacle. The probe is held in place with 4 retention detents.



Ostby Barton
A Division of Everett
Charles Technologies
487 Jefferson Boulevard
Warwick, RI 02886
Tel: (401) 739-7310
Fax: (401) 732-4937
Internet: ectinfo.com

DOVER A Dover Company

8018-8-03-156